

# Outdoor Poly Tank Specification

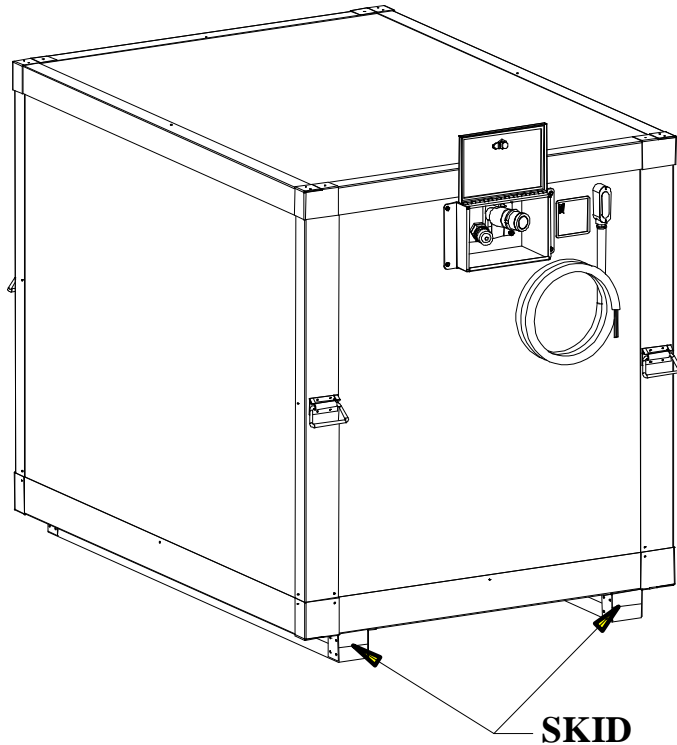

- Length: 62-1/2 inches
- Width: 44-1/2 inches
- Height: 51-1/4 inches
  - Includes 2" skid attached to bottom
  - Fill box door will stick up additional 3" when open



- Vessel Material
  - Oil Tanks: Food-Grade Polyethylene
  - Enclosure: Aluminum
- 120 VAC (maximum draw = 25 amp)
- Net Storage Capacity
  - 973 lbs. clean oil,
  - 823 lbs. waste oil.
  - (823+150=973. Including 150 lbs. of residual oil when tank is emptied)*
- Tare Weight of Oil Tanks
  - 120 lbs. clean oil tank
  - 120 lbs. waste oil tank.
- Gross Weight of Oil Tanks
  - 1093 lbs. clean oil tank
  - 1093 lbs. waste oil tank
- Enclosure weight: Approximately 500 lbs.
- Features:
  - Overfill switch provided on both tanks.
  - Enclosure is electrically heated.
  - Clean oil tank provided with remote level gauge that reads in "pounds of oil" inside restaurant.
  - Space inside enclosure for locating supporting equipment.
  - Clean oil tank certified by NSF to ANSI/NSF Standard 4 Component
  - Complies with applicable requirements of UL 499

# Indoor Poly1.4k Tank Specifications

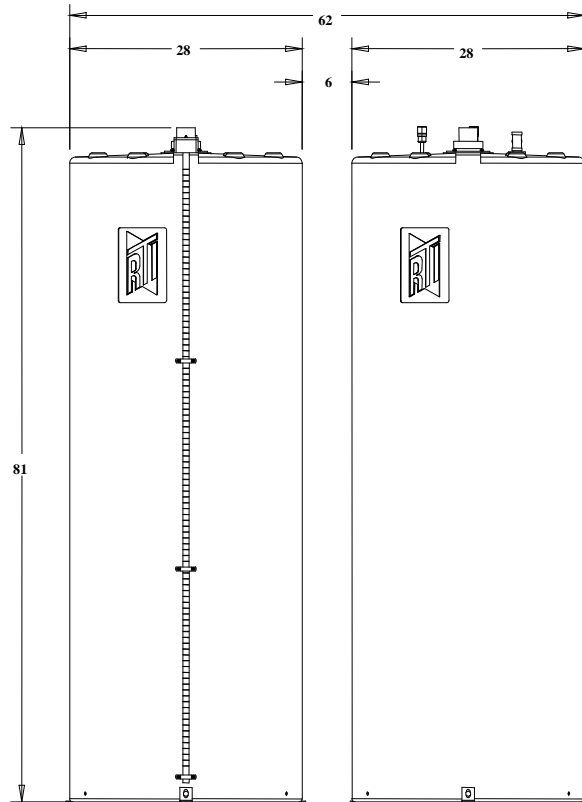

- Tank Height = 81"
- Tank Diameter = 28"
- Vessel Material = Food-Grade Polyethylene
- Net Storage Capacity
  - 1430 lbs. clean oil,
  - 1228 lbs. waste oil.  
*(1228+150=1378. Including 150 lbs. of residual oil when tank is emptied)*
- Tare Weight of Oil Tanks
  - 82 lbs. clean oil tank
  - 142 lbs. waste oil tank.
- Gross Weight of Oil Tanks
  - 1512 lbs. clean oil tank
  - 1520 lbs. waste oil tank
- Features:
  - Tank provided with mounting inserts to secure to floor.
  - Overfill switch provided on both tanks.
  - Waste oil tank is heated.
  - Clean oil tank provided with accurate level gauge that reads in "pounds of oil" inside restaurant.
  - Space above oil tanks for locating supporting equipment.
  - Certified by NSF to ANSI/NSF Standard 4

# Indoor Poly Tank Specifications

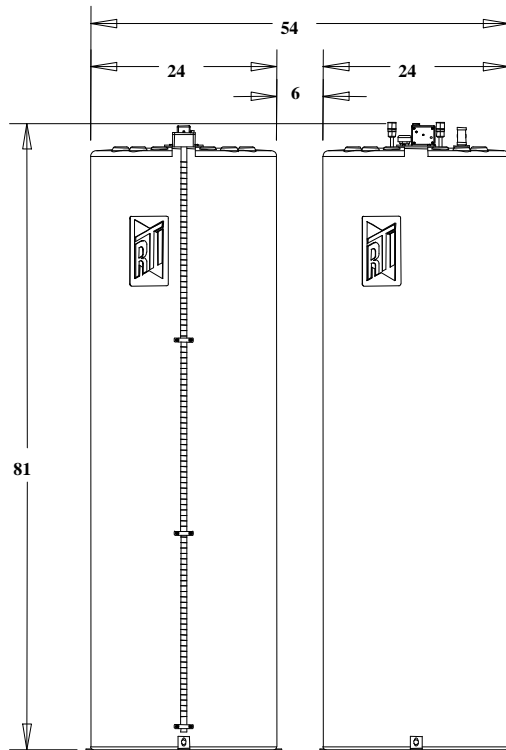

- Tank Height = 81”
- Tank Diameter = 24”
- Net Storage Capacity
  - 1045 lbs. clean oil,
  - 860 lbs. waste oil.  
*(860+150=1010. Including 150 lbs. of residual oil when tank is emptied)*
- Tare Weight
  - 72 lbs. clean oil tank
  - 132 lbs. waste oil tank.
- Gross Weight
  - 1117 lbs. clean oil tank
  - 1142 lbs. waste oil tank
- Vessel Material = Food-Grade Polyethylene
- Features:
  - Tanks provided with mounting inserts to secure to floor.
  - Overfill protection provided on both tanks.
  - Waste oil tank is heated.
  - Clean oil tank provided with accurate level gauge that reads in “pounds of oil”.
  - Space above oil tanks for locating supporting equipment.
  - Certified by NSF to **ANSI/NSF Standard 4**
  - Universal base available.

